

CONTACT DATA

INSERTION / EXTRACTION FORCE GRAPHS

#18 CONTACT

FOR .037"-.043" DIAMETER PINS ($\delta = .004$)
6-FINGER, GROUP L (See page 248)

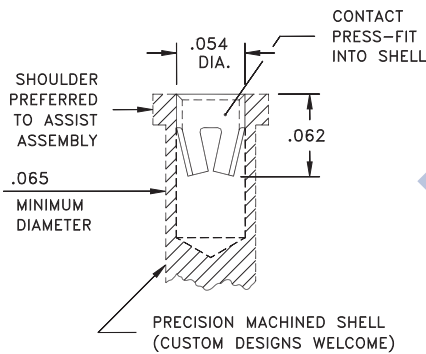

CONTACT MATERIAL
BERYLLIUM COPPER
Alloy 172,
Heat Treated

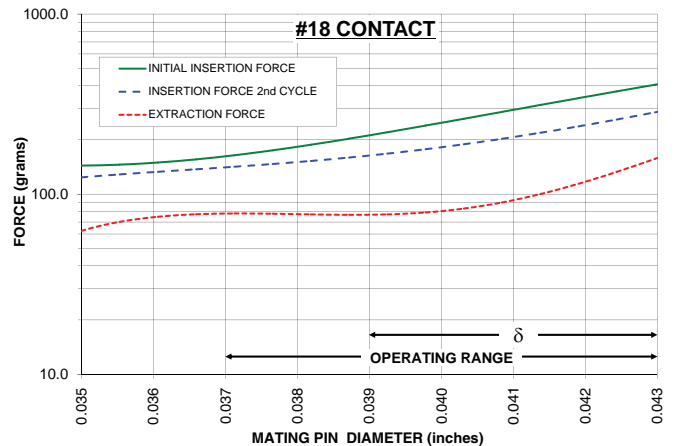

#58 CONTACT

FOR .037"-.043" DIAMETER PINS ($\delta = .003$)
6-FINGER, GROUP L (See page 248)

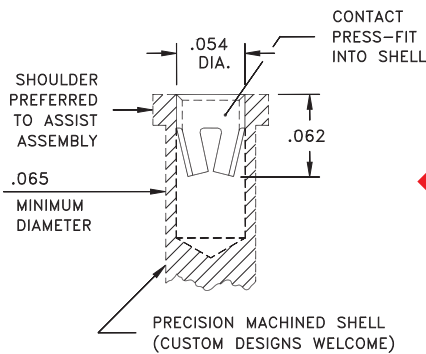

CONTACT MATERIAL
BERYLLIUM NICKEL
Alloy 360,
Heat Treated

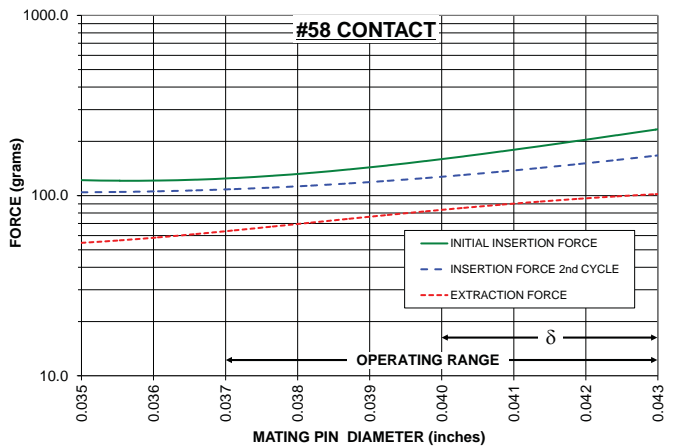

#36 CONTACT

FOR .022"-.042" DIAMETER PINS ($\delta = .022$)
4-FINGER, GROUP E (See page 248)

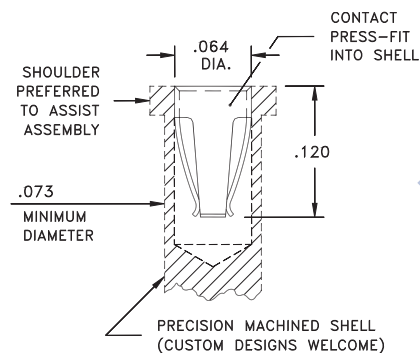

CONTACT MATERIAL
BERYLLIUM COPPER
Alloy 172,
Heat Treated

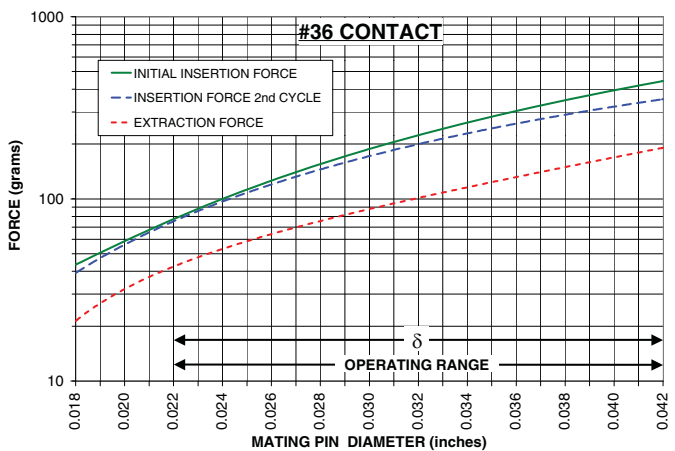

The insertion / extraction force characteristics above were derived using a 30 microinch gold-plated contact and polished steel gauge pins having a bullet-shaped tip.

The curves represent typical average values; they are best used to compare the differences between similar size contacts and to guide you in selecting one that is suitable for your application. Your results may vary, so for your specification, we encourage you to obtain complimentary samples for your evaluation.

